

NOTES:

1. SYSTEM MANIFOLD CONNECTIONS ARE GROOVED. (CLASS 125/150 OR 250/300 ANSI FLANGED OPTIONAL)
2. IF OPTIONAL TANK IS PROVIDED, ONE FIELD CONNECTION IS REQUIRED.
3. DATA IS BASED ON FXA-700 TANK. REFER TO TANK DRAWINGS FOR DIMENSIONS AND WEIGHTS OF OTHER MODELS.
4. MAXIMUM SYSTEM PRESSURE MUST NOT EXCEED (175) (250) (300) PSIG OR OPTIONAL ADJACENT TANK PRESSURE RATING.
5. RIGHT HAND SYSTEM IS SHOWN. SPECIFY LEFT HAND IF REQUIRED.
6. FOR DIMENSIONS AND DRY WEIGHT CHOOSE THE LARGEST HP PUMP USED IN THE SYSTEM.
7. CUSTOM DIMENSIONS ARE AVAILABLE, CONSULT FACTORY.
- 8.* VFD'S OVER 15 HP MAY REQUIRE 84"

SYSTEM SUCTION AND DISCHARGE CONNECTIONS:

- GROOVED END (SHOWN)
- CLASS 125/150 ANSI FLANGED (NOT SHOWN)
- CLASS 250/300 ANSI FLANGED (NOT SHOWN)

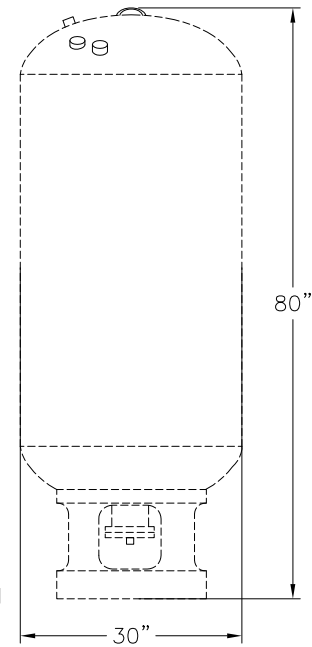
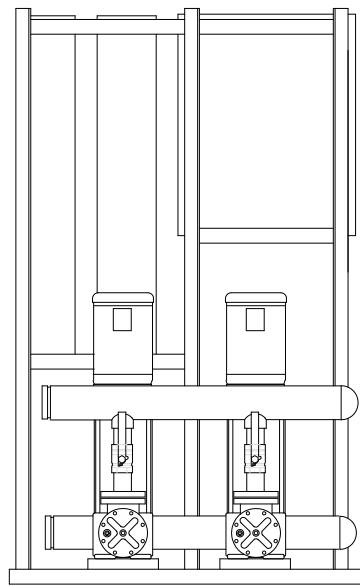
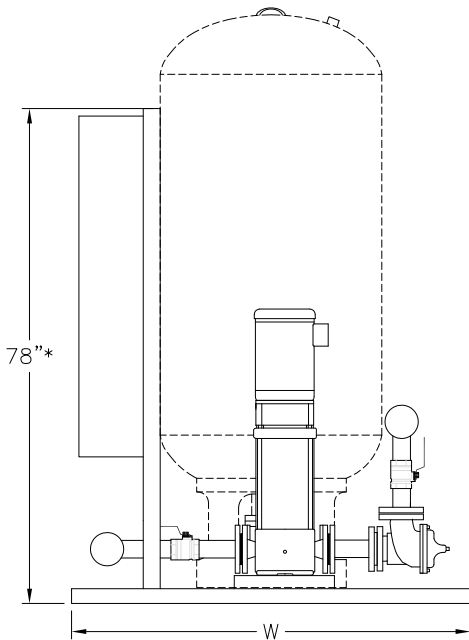
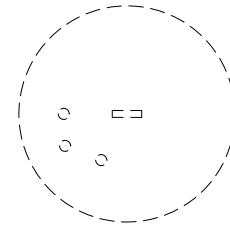
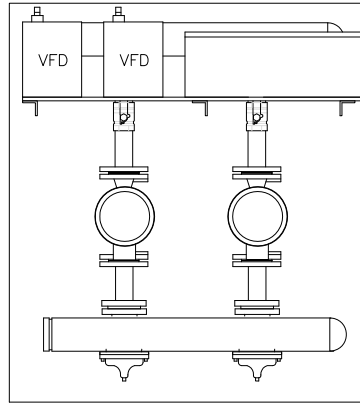

| DIMENSIONS IN INCHES (APPROX.) | | | SYSTEM WEIGHT IN LBS. (APPROX.) | |
|--------------------------------|----|----|---------------------------------|-----------|
| MODEL | L | W | WITHOUT TANK | WITH TANK |
| CR1S-CR5 | 40 | 48 | 900 | 1500 |
| CR10-CR20 | 40 | 54 | 1300 | 1900 |
| CR32-CR45 | 46 | 60 | 2100 | 2600 |
| CR64-CR90 | 50 | 68 | 2400 | 2900 |

Not for construction purposes unless certified.

CERTIFIED BY: _____ DATE: _____