

1. IF OPTIONAL TANK IS PROVIDED, ONE FIELD CONNECTION IS REQUIRED.
2. DATA IS BASED ON FX-300V TANK. REFER TO TANK DRAWINGS FOR DIMENSIONS AND WEIGHTS OF OTHER MODELS.
3. MAXIMUM SYSTEM PRESSURE MUST NOT EXCEED 175 PSIG OR ADJACENT TANK PRESSURE RATING.

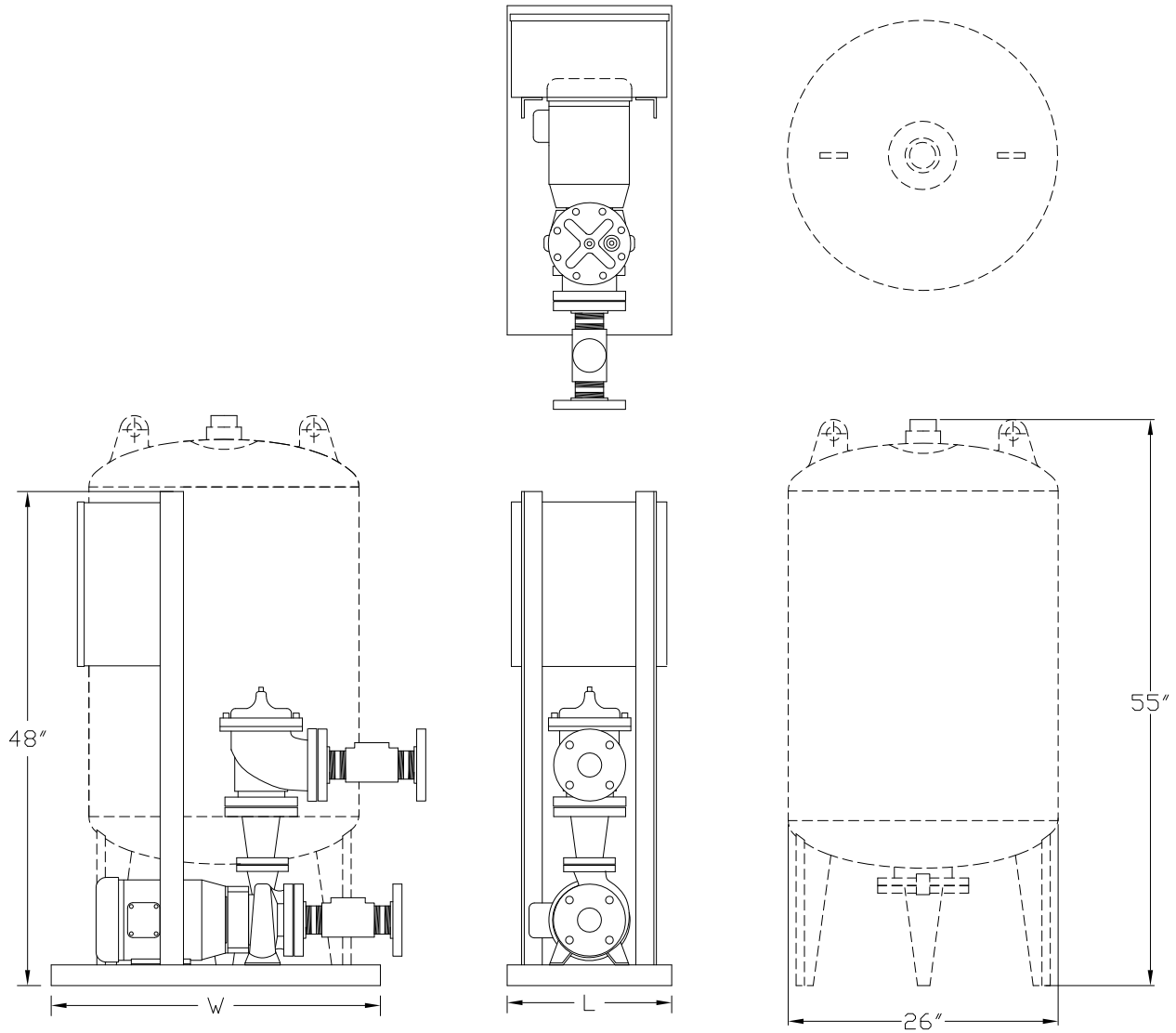

DIMENSIONS IN INCHES (APPROX.)			SYSTEM WEIGHT IN LBS. (APPROX.)	
HORSEPOWER PER PUMP	L	W	WITHOUT TANK	WITH TANK
2-3 HORSEPOWER	16	32	230	370
5-7.5 HORSEPOWER	16	32	290	430
10-15 HORSEPOWER	16	32	360	500
20-25 HORSEPOWER	20	36	600	740

Not for construction purposes unless certified.

CERTIFIED BY: \_\_\_\_\_ DATE: \_\_\_\_\_