

NOTES:

1. SYSTEM MANIFOLD CONNECTIONS ARE GROOVED. (CLASS 125/150 ANSI FLANGED OPTIONAL)
2. DATA IS BASED ON FXA-700 TANK. REFER TO TANK DRAWINGS FOR DIMENSIONS AND WEIGHTS OF OTHER MODELS.
3. MAXIMUM SYSTEM PRESSURE MUST NOT EXCEED 175 PSIG OR OPTIONAL ADJACENT TANK PRESSURE RATING.
4. RIGHT HAND SYSTEM IS SHOWN. SPECIFY LEFT HAND IF REQUIRED.
5. FOR DIMENSIONS AND DRY WEIGHT CHOOSE THE LARGEST HP PUMP USED IN THE SYSTEM.
6. CUSTOM DIMENSIONS ARE AVAILABLE, CONSULT FACTORY.
7. * VFD'S OVER 15 HP MAY REQUIRE 84"

SYSTEM SUCTION AND DISCHARGE CONNECTIONS:

- GROOVED END (SHOWN)
- CLASS 125/150 ANSI FLANGED (NOT SHOWN)

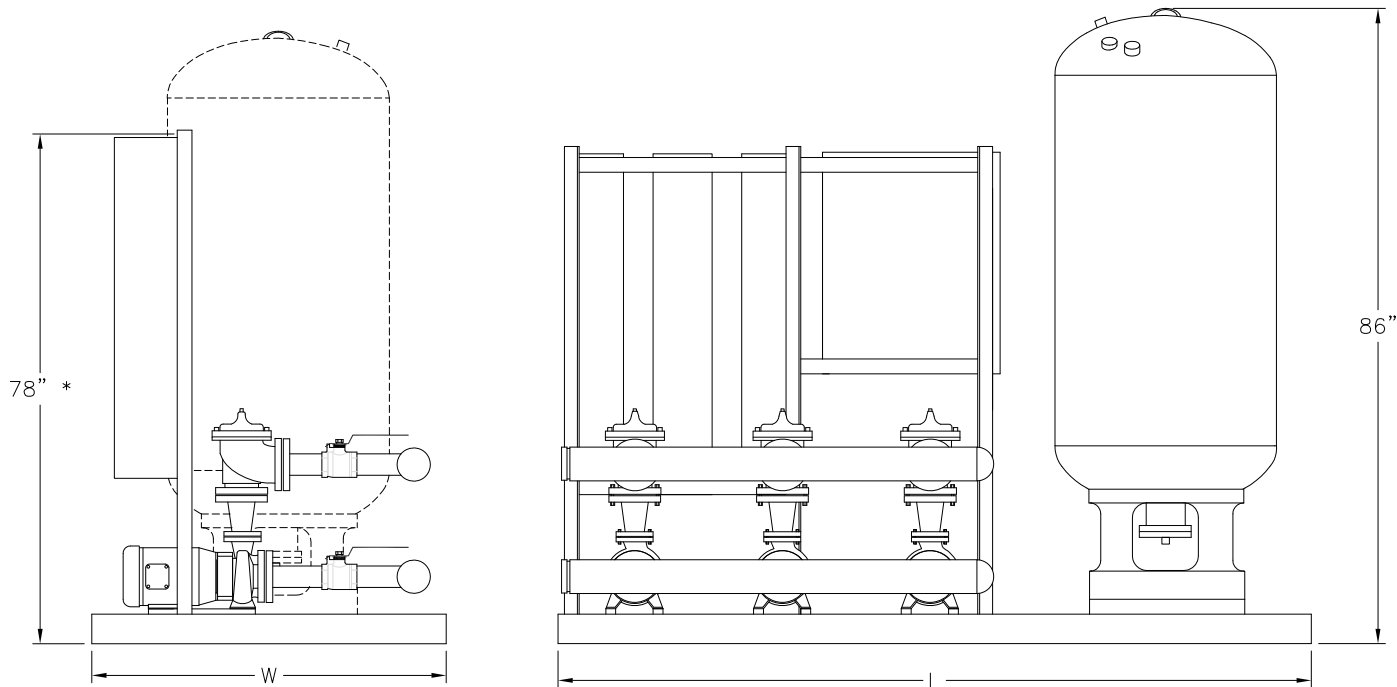
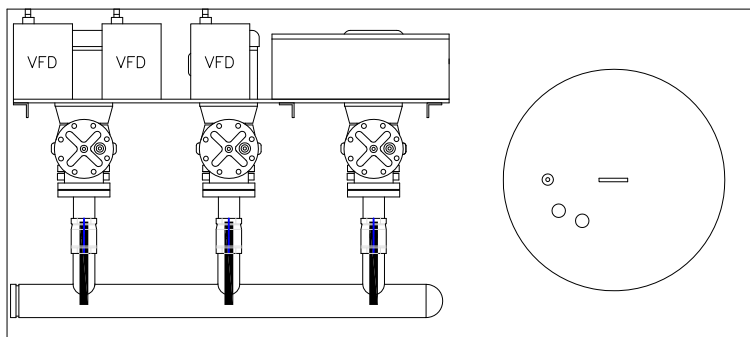

DIMENSIONS IN INCHES (APPROX.)			SYSTEM WEIGHT IN LBS. (APPROX.)
HORSEPOWER PER PUMP	L	W	
2-3 HORSEPOWER	108	44	1900
5-7.5 HORSEPOWER	112	50	2100
10-15 HORSEPOWER	116	58	2600
20-25 HORSEPOWER	120	64	2800

Not for construction purposes unless certified.

CERTIFIED BY: _____ DATE: _____