

NOTES:

1. SYSTEM MANIFOLD CONNECTIONS ARE GROOVED. (CLASS 125/150 ANSI FLANGED OPTIONAL)
2. DATA IS BASED ON FXA-700 TANK. REFER TO TANK DRAWINGS FOR DIMENSIONS AND WEIGHTS OF OTHER MODELS.
3. MAXIMUM SYSTEM PRESSURE MUST NOT EXCEED 175 PSIG OR OPTIONAL ADJACENT TANK PRESSURE RATING.
4. RIGHT HAND SYSTEM IS SHOWN. SPECIFY LEFT HAND IF REQUIRED.
5. FOR DIMENSIONS AND DRY WEIGHT CHOOSE THE LARGEST HP PUMP USED IN THE SYSTEM.
6. CUSTOM DIMENSIONS ARE AVAILABLE, CONSULT FACTORY.

SYSTEM SUCTION AND DISCHARGE CONNECTIONS:

- GROOVED END (SHOWN)
- CLASS 125/150 ANSI FLANGED (NOT SHOWN)

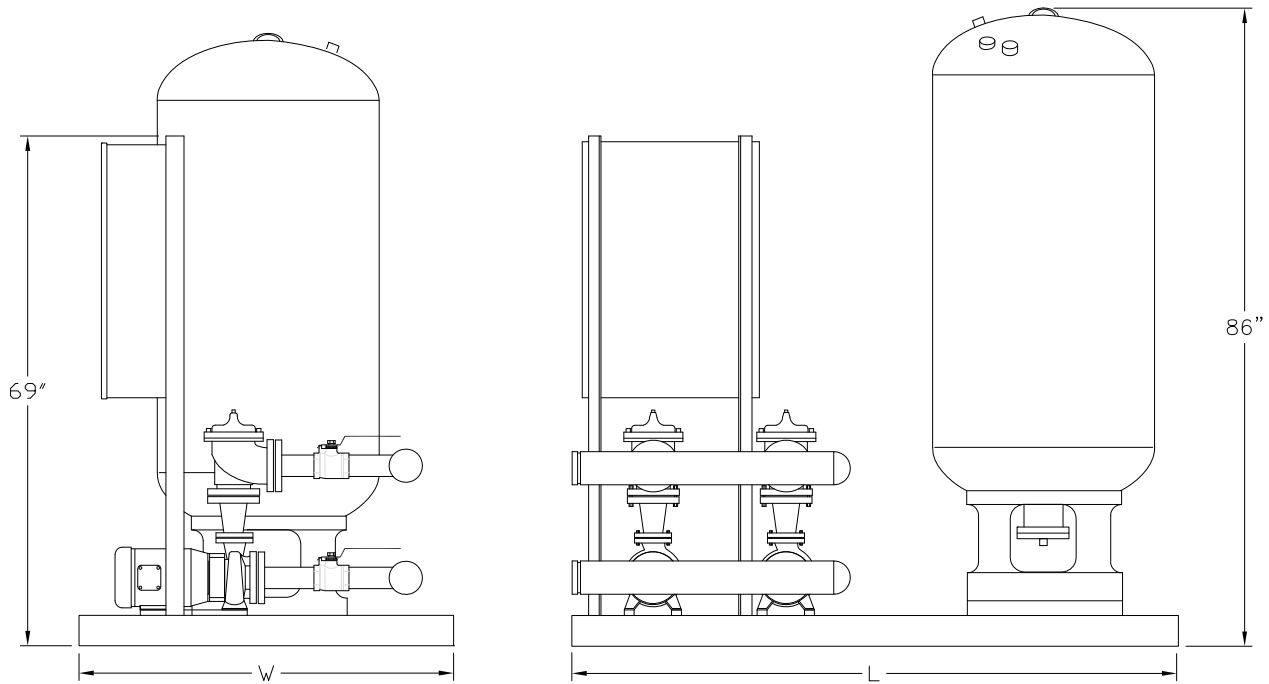
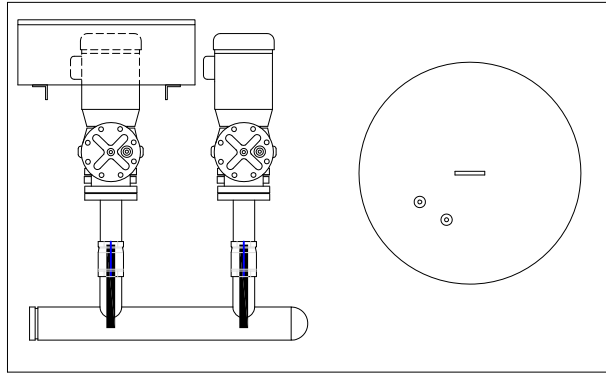

DIMENSIONS IN INCHES (APPROX.)			SYSTEM WEIGHT IN LBS. (APPROX.)
HORSEPOWER PER PUMP	L	W	
2-3 HORSEPOWER	82	42	1500
5-10 HORSEPOWER	82	42	1700
15-25 HORSEPOWER	86	58	2000

Not for construction purposes unless certified.

CERTIFIED BY: \_\_\_\_\_ DATE: \_\_\_\_\_

DUPLEX END SUCTION	CANARIIS CORPORATION		
WITH SKID MOUNTED TANK	DATE: 01/05/09	SCALE: NTS	www.canariis.com