

NOTES:

1. MAXIMUM SYSTEM PRESSURE MUST NOT EXCEED 150 PSIG.

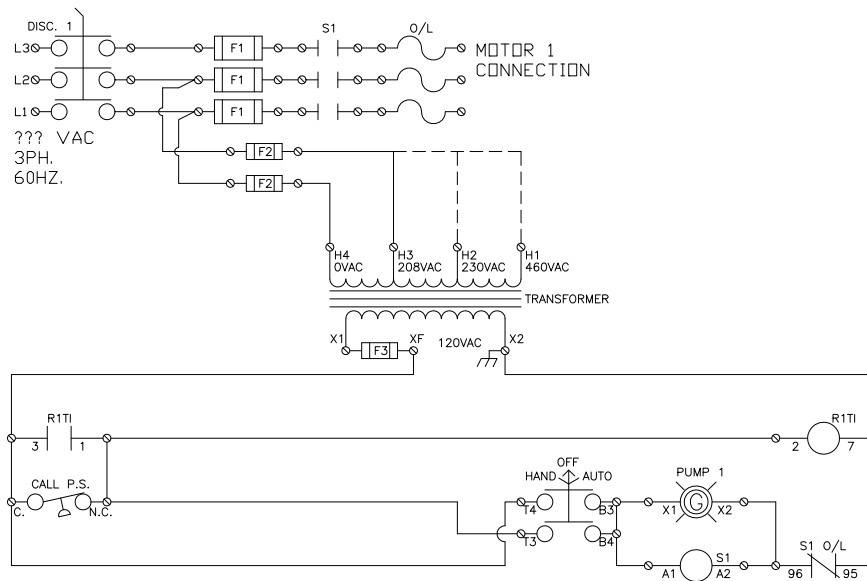
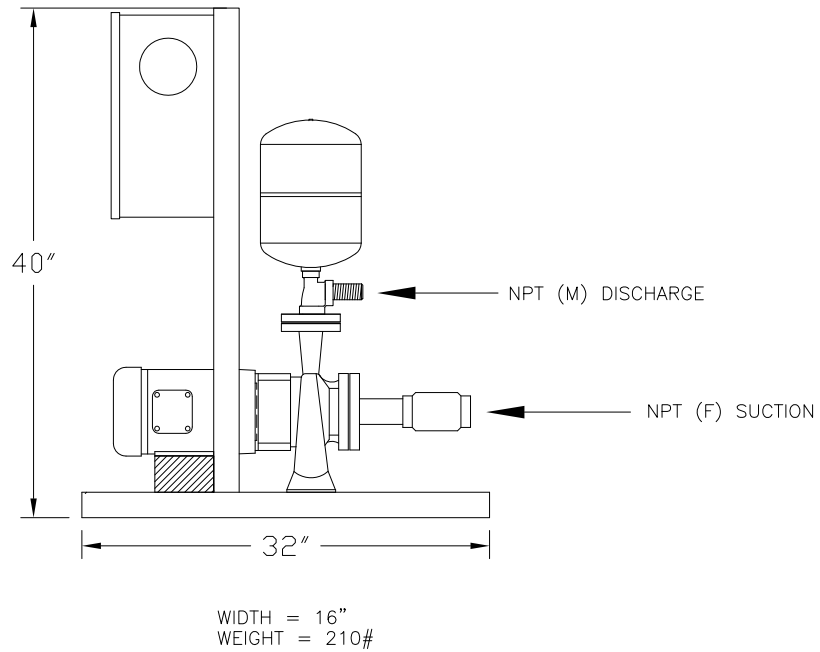

FUSE DETAIL

CAUTION: TO REDUCE THE RISK OF FIRE, REPLACE ONLY WITH SAME TYPE AND RATING OF FUSE.

FUSE#	TYPE	SIZE
F1	TR	?A
F2	KLDR	1A
F3	FLQ	.8A

MCA = 20 AMPS.
Use Copper Conductor Only.
60 Deg C For Less Than 100 Amps.
75 Deg C For 100 Amps. And Greater.
Adjust O/L Setting For Motor FLA.

TIMER DETAIL

R1TI - MIN. RUN TIMER FOR PUMP CALL

Short Circuit Current: 5kA rms symmetrical,
600V maximum with 460V supply
250V maximum with 208-230V supply.